



ECHOLS METAL

INSTALLATION GUIDE

▶ **IMPORTANT NOTE**

The illustration and drawings in the booklet are for the Low Rib (AG) type roofing panel.

The same principles and techniques may be used when installing the PBR (R-Panel) and Apex panel type roofing system as well.

Please note that some trim dimensions will change accordingly to accommodate the change in rib height from Low Rib(AG) to PBR(RPanel).

Please see the trim detail illustrations in the back of the booklet for accurate trim dimensions.

▶ **SAFETY**

STUDY APPLICABLE OSHA AND OTHER SAFETY REQUIREMENTS BEFORE FOLLOWING THESE INSTRUCTIONS.

Safety railing, netting, harnesses and safety lines should be provided and used by all crew members working on the roof.

All personal protective equipment (i.e. gloves, safety glasses, long sleeves, long pants, hard hats) should be worn when installing or handling products.



▶ MATERIAL STORAGE

- Unload material and inspect for damage. Notify your sales contact immediately for all damaged material.
- It is recommended that pre-painted material be stored in an indoor facility isolated from the elements. If material must be stored outside proper precaution must be taken.
- If bundles are stored on the ground, a plastic cover must be put down under the bundle to minimize condensation of water from the ground onto the panels. The bundles must be raised off the plastic ground cover to avoid contact with water puddles and allow for air circulation around the bundles to promote drying of condensed water. The panels must be stored at an angle to promote drainage of water off the bundle. Sufficient support must be provided to the raised and angled bundles to avoid excessive bowing, which may result in low spots that could hold water.
- The bundle must be completely sheltered with a loose fitting waterproof tarp to protect the bundle during rain or snow events, but allow for air circulation and drying of condensed water.
- In addition to water there are other important factors that contribute to the corrosion of stored, pre-painted panels. These factors are temperature and exposure time. Given enough time, panels will eventually become wet and storage corrosion may occur under most job site conditions. Even in a well protected bundle the natural temperature and humidity variations will cause water to condense on and between the panels. Shipping the bundle from cold area to a warm area will cause water to condense not only on the bundle but also between the panels.

In conclusion, storage corrosion can be prevented by:

1. Decreasing water contact.
2. Moderating temperature extremes.
3. Immediately drying moisture exposed bundles.
4. Reducing site storage time.

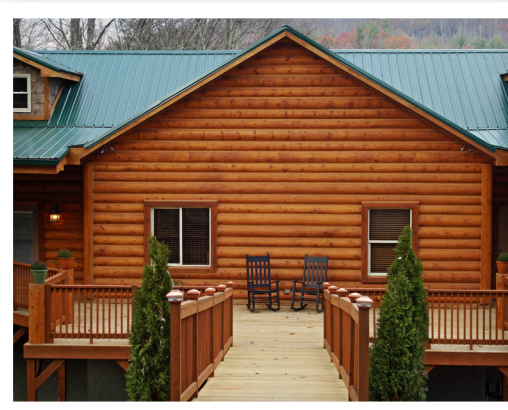

▶ INTRODUCTION

The application and detail drawings in this manual are strictly for illustration purposes and may not be applicable to all building designs or product installations. All projects should conform to applicable building codes for that particular area. It is recommended to follow all building regulations and standard industry practices. If there is a conflict between the instructions in this manual and actual building codes or erection drawings, the building codes and erection drawings are to take precedence.

Prior to ordering and installing materials, all dimensions should be verified by field measurements.

We reserve the right to modify, without notice, any details, recommendations or suggestions. Any questions you may have regarding proper installation of the LOW RIB (AG), PBR (R-Panel), or Apex panel roofing system should be directed to us.

Consult us for any additional information not outlined in this manual.

This manual is designed to be utilized as a guide when installing the LOW RIB (AG), PBR (R-Panel), or Apex panel roofing system. It is the responsibility of the erector to ensure safe installation that results in the proper performance of this product system.



▶ CUTTING

Tin snips or a “nibbler” type electric tool are recommended for field cutting of panels. Cutting the steel generates slivers and metal chips. These slivers and metal chips must be immediately removed from the panels because they could damage the finish and shorten the life span of the product.

Although we do not recommend it, if you decide to cut with a saw, it is very important that the panels be turned upside down during the cutting so that hot shavings do not come in contact with the painted surface. Make sure all adjacent panels are covered so that shavings are not embedded in these panels. If metal shavings become embedded in the paint surface, they will quickly rust. To avoid this, panels should be thoroughly wiped of all filings on both sides of the panel. Failure to comply with the recommended cutting procedures releases the manufacturer of any responsibility.

▶ RECOMMENDED TOOLS

Screw Gun

Clutch type screw gun allowing for variable torque settings with depth locating nose piece is recommended to insure proper installation of the screws. The following bits will be required:

- ¼" Hex
- 5/16" Hex
- #2 Phillips Screw Driver Bit

Snips

For cutting miscellaneous panels and flashing, three pair of compound snips will be required for left edge, right edge and centerline cuts.

Caulking Gun

For miscellaneous caulking and sealing to inhibit water infiltration.

Pop Rivet Tool

Used for miscellaneous flashing and trim applications.

Locking Pliers

Standard and "Duck Bill" styles for miscellaneous clamping and bending of parts.

▶ RECOMMENDED FASTENING PATTERNS

LOW RIB (AG) PANEL

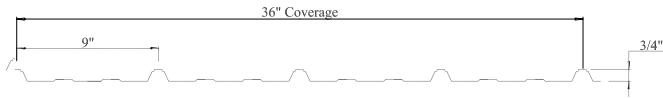

SCREW FASTENERS - EAVE, RIDGE & ENDLAPS



SCREW FASTENERS - INTERMEDIATE SUPPORTS

PBR (R-PANEL)



SCREW FASTENERS - EAVE, RIDGE & ENDLAPS



SCREW FASTENERS - INTERMEDIATE SUPPORTS

APEX PANEL

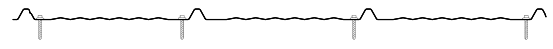
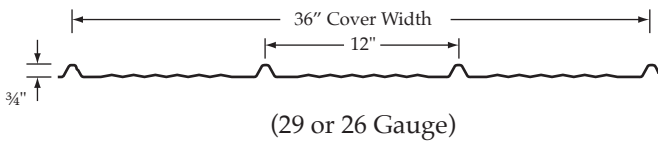

SCREW FASTENERS - INTERMEDIATE SUPPORTS



SCREW FASTENERS - EAVE, RIDGE & ENDLAPS



OVERLAP DETAIL

RIDGE CAP ILLUSTRATION

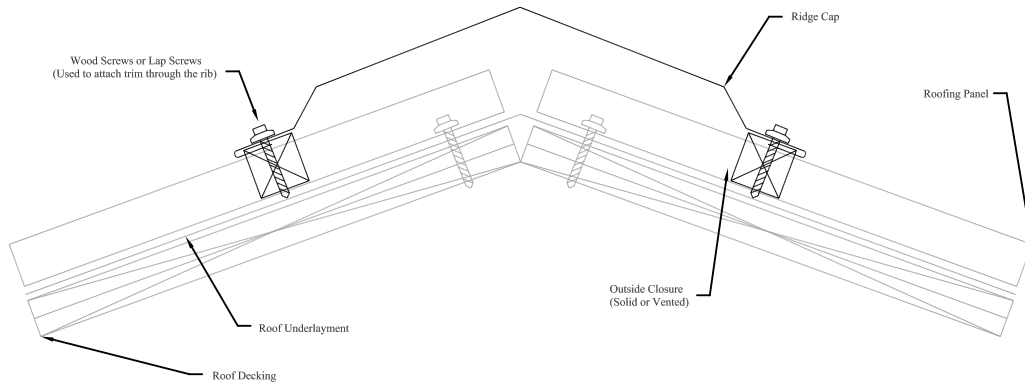

*Required Items: Ridge Cap, Outer Closure, Screws.

DRIP EDGE INSTALLATION ILLUSTRATION

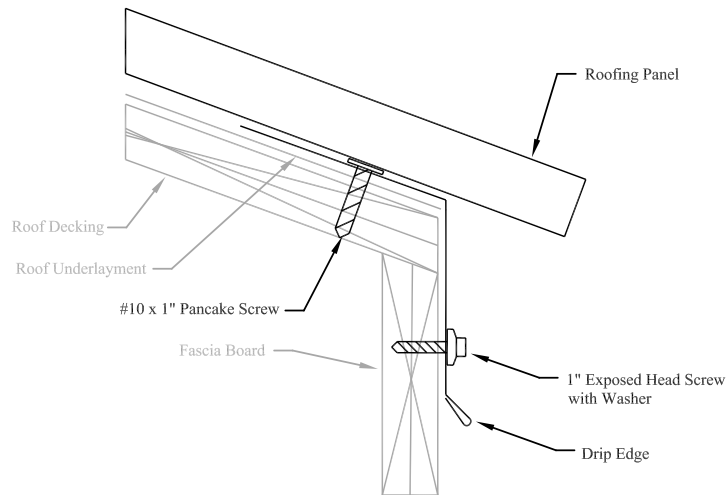

*Required Items: Drip Edge, Pancake Screws and Exposed Head Screws.

RAKE TRIM ILLUSTRATION

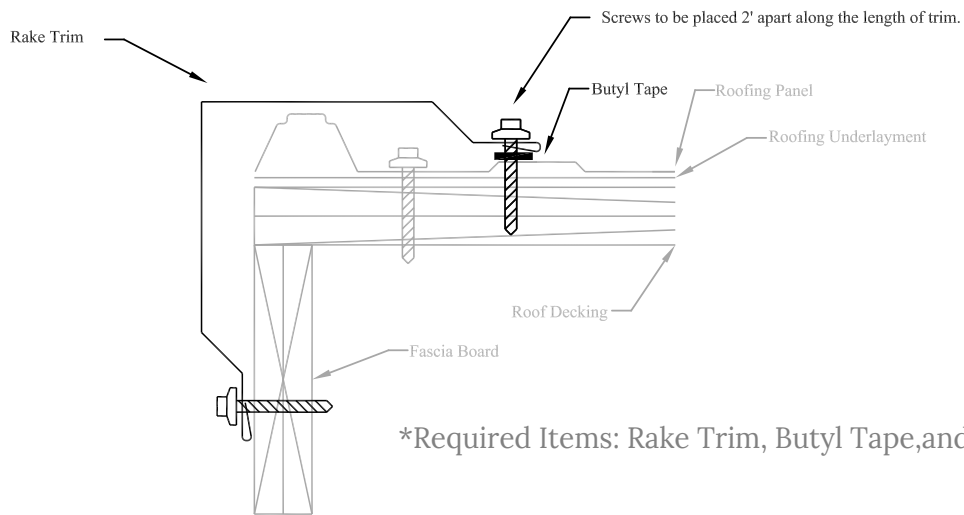

*Required Items: Rake Trim, Butyl Tape, and Screws

VALLEY INSTALLATION ILLUSTRATION

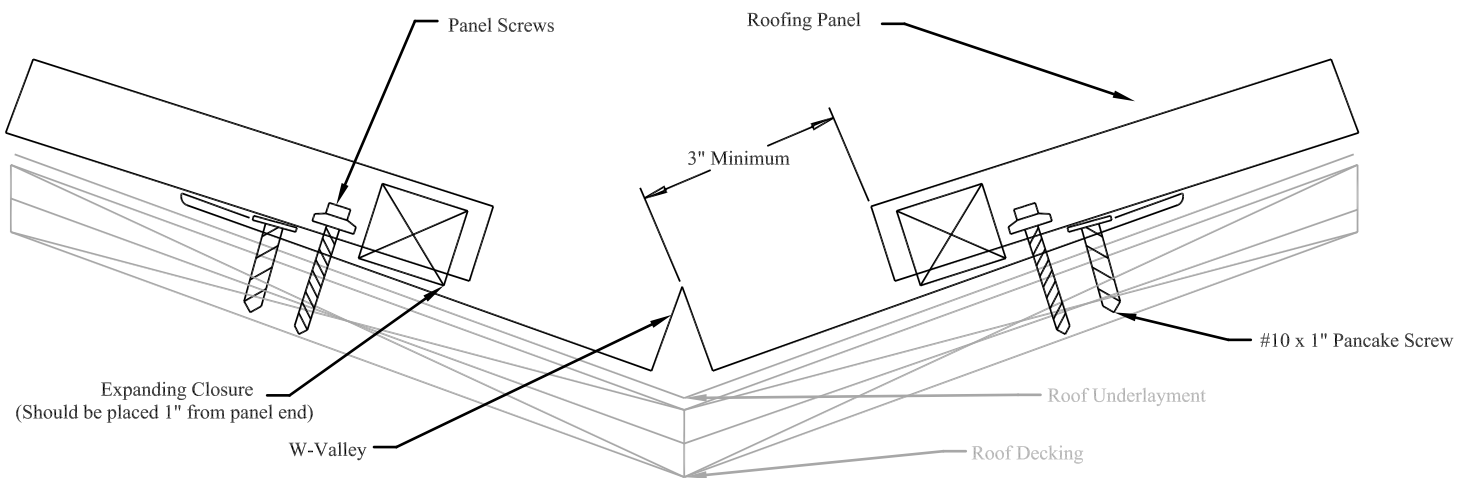

*Required Items: Valley, Expanding Closure, Panel Screws and Pancake Screws

ENDWALL INSTALLATION ILLUSTRATION

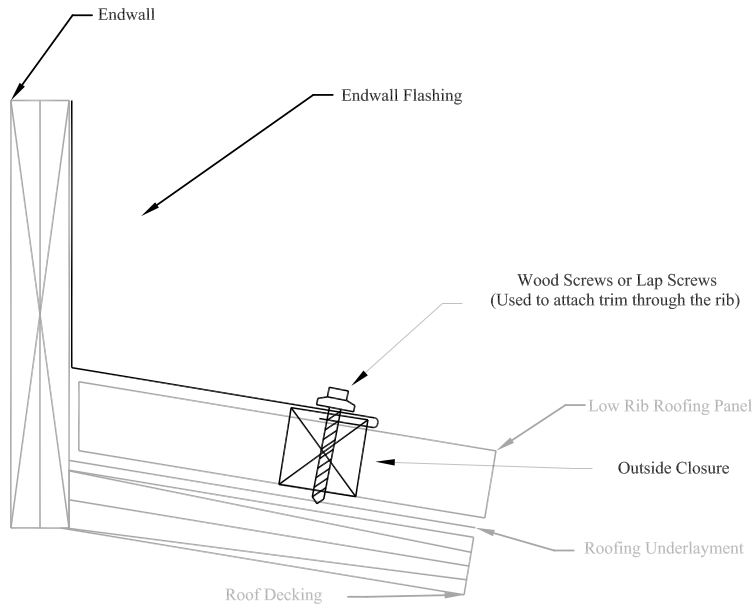

*Required Items: Endwall Trim, Screws and Outside Closure.

PITCH CHANGE INSTALLATION ILLUSTRATION

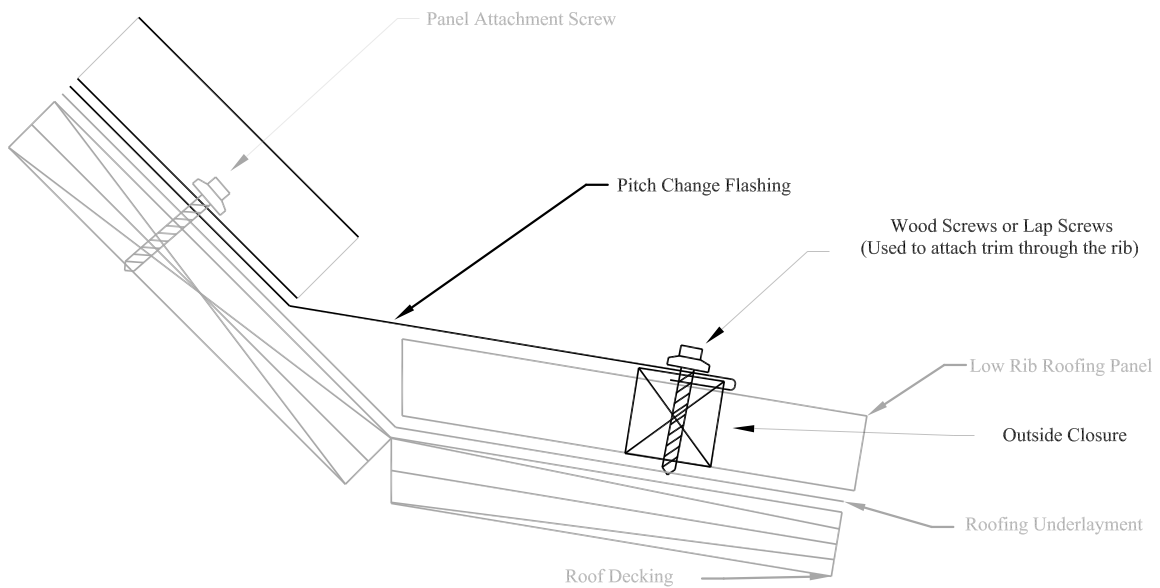

*Required Items: Pitch Change Flashing, Screws and Outside Closure.

SIDEWALL INSTALLATION ILLUSTRATION

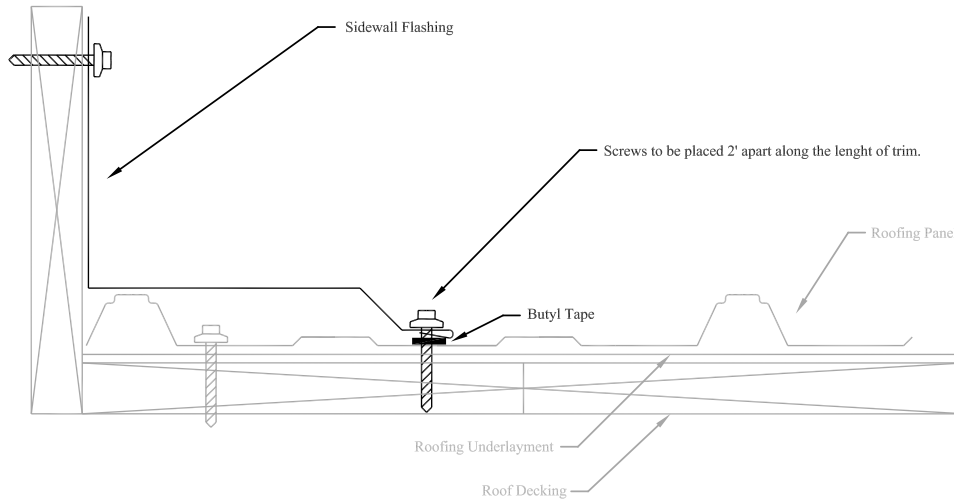

*Required Items: Sidewall Trim, Butyl Tape, and Screws

RIDGE CAP

*Not to scale

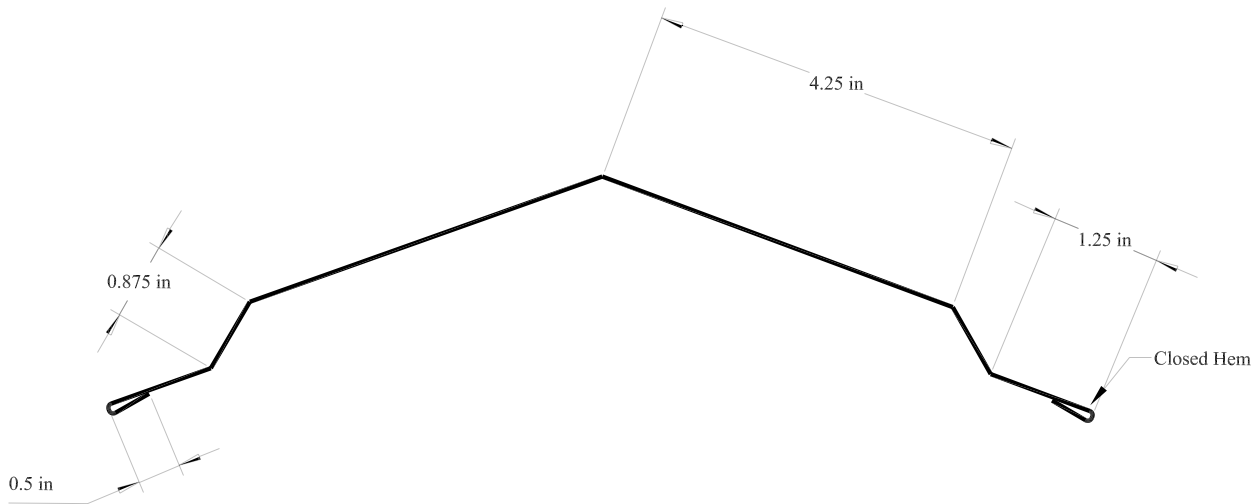

9" x 9" RIDGE CAP

*Not to scale

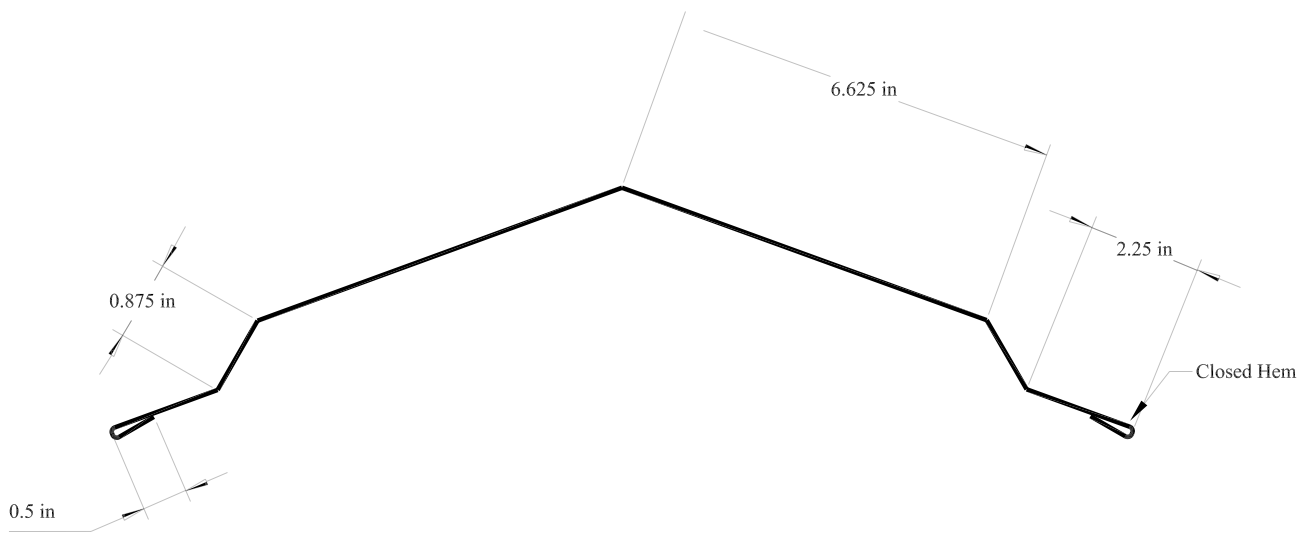

DRIP TRIM (2 X 2 WITH KICK NO HEM)

*Not to scale

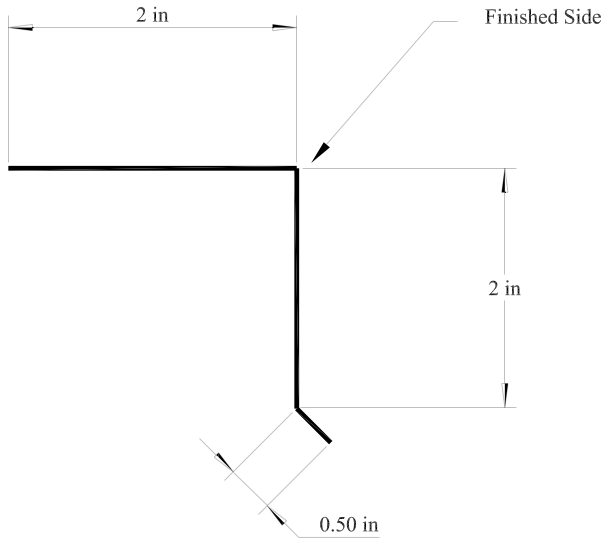

2 X 2 EAVE (DRIP) TRIM

*Not to scale

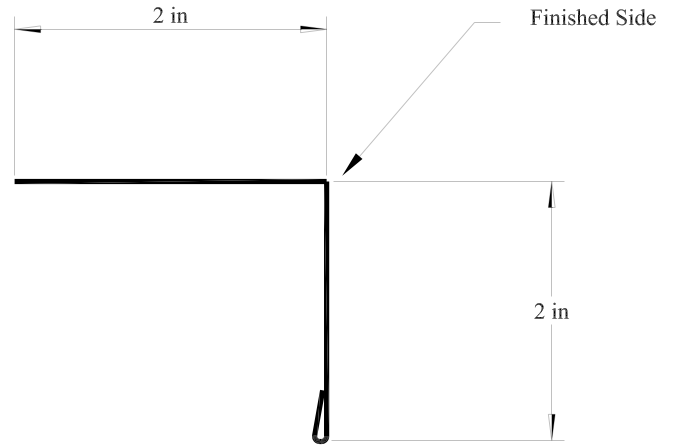

3 X 3 EAVE (DRIP) TRIM WITH KICKOUT

*Not to scale

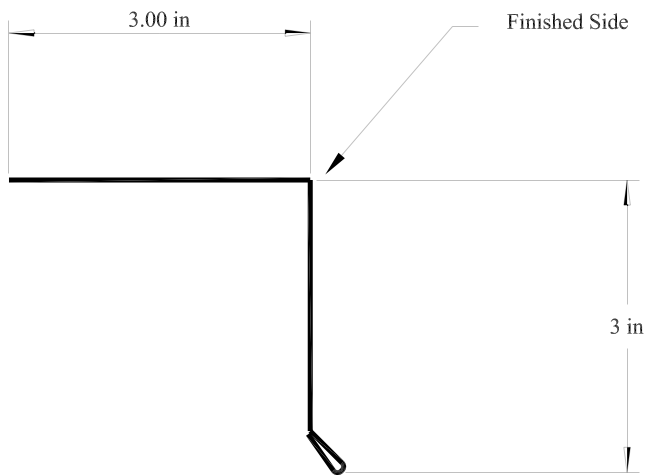

POST TRIM (DRIP EDGE)

*Not to scale

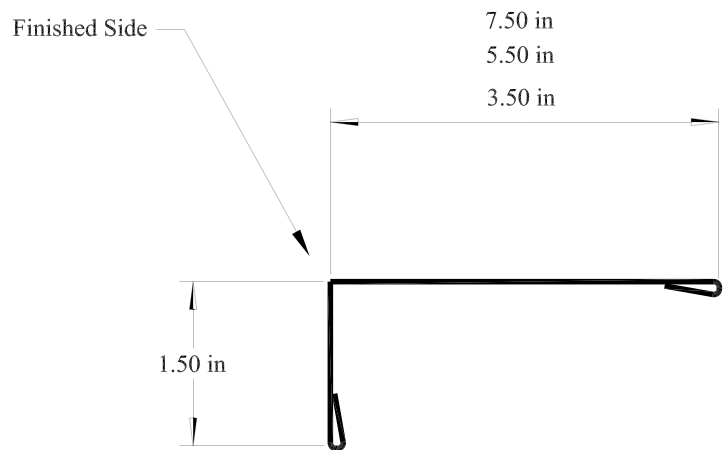

SMALL CORNER

*Not to scale

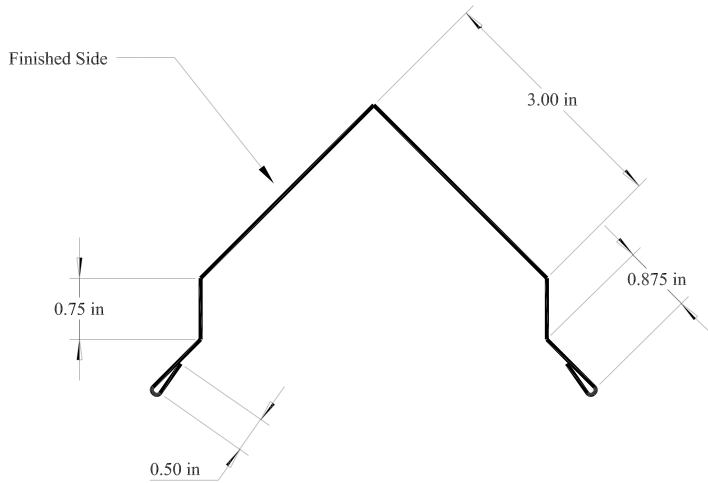

LARGE CORNER

*Not to scale

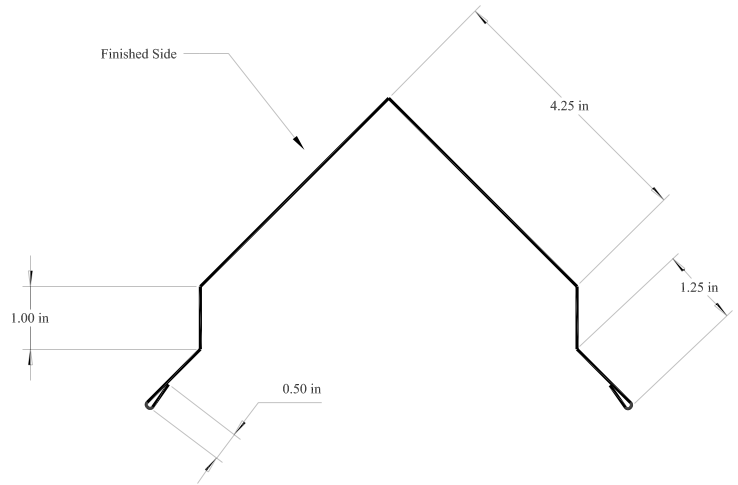

DENVER RAKE AND CORNER TRIM

*Not to scale

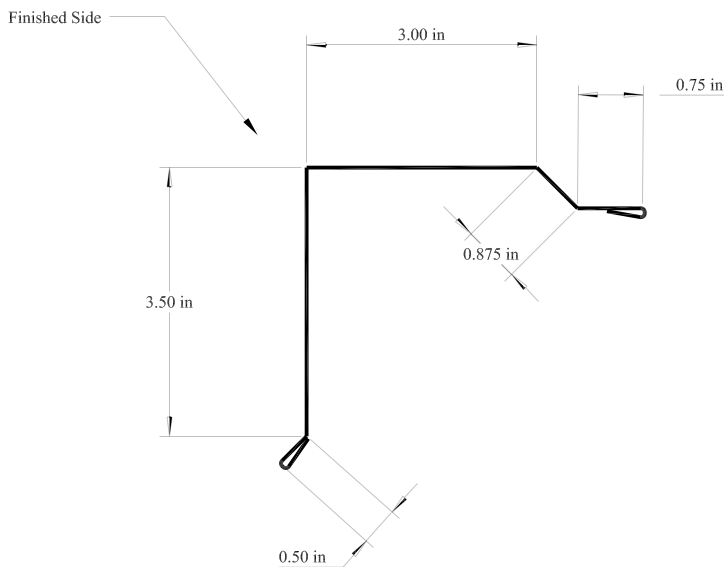

INSIDE CORNER

*Not to scale

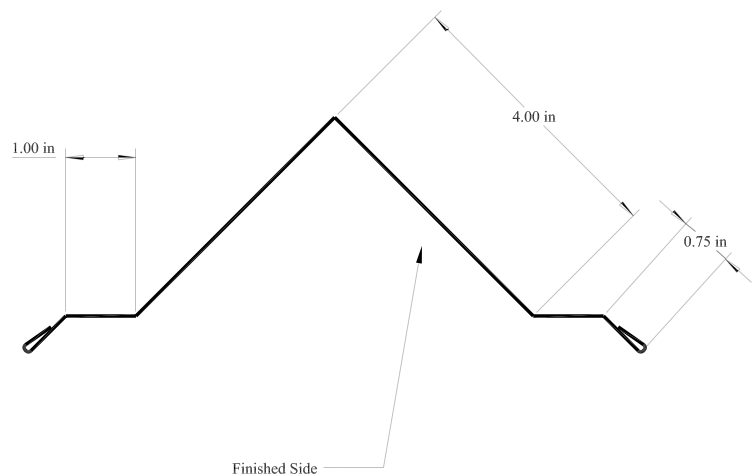

SPECIAL RAKE TRIM

*Not to scale

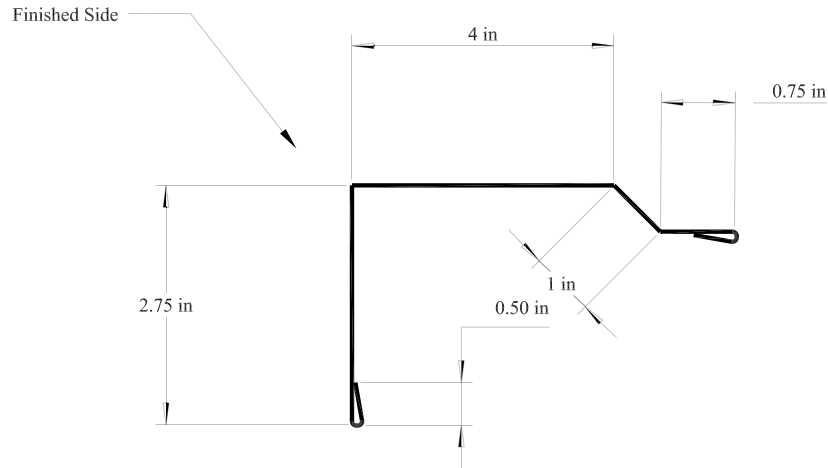

W-VALLEY

*Not to scale

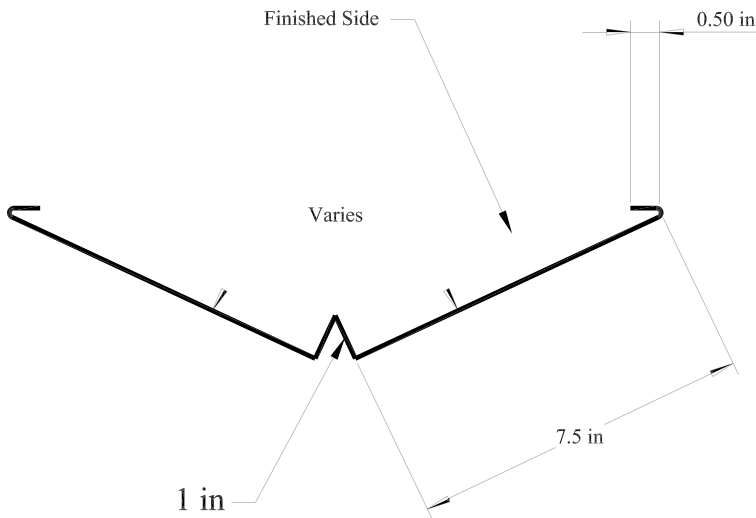

**LARGE W - VALLEY
(12" IN FLATS)**

*Not to scale

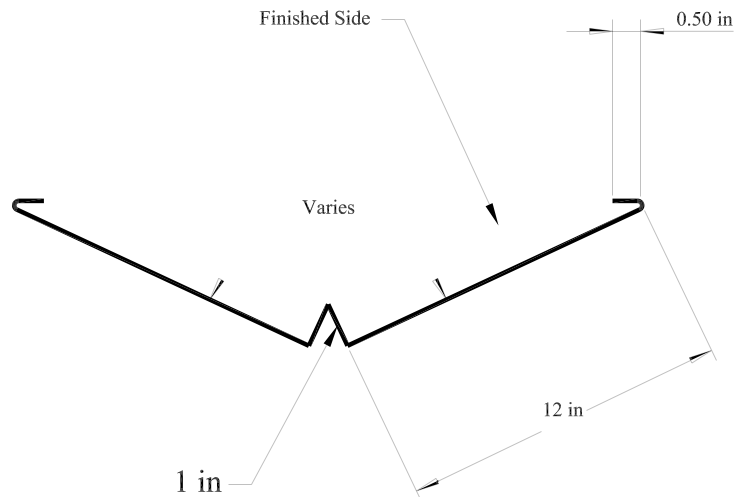

4 X 6 WALL FLASHING

*Not to scale

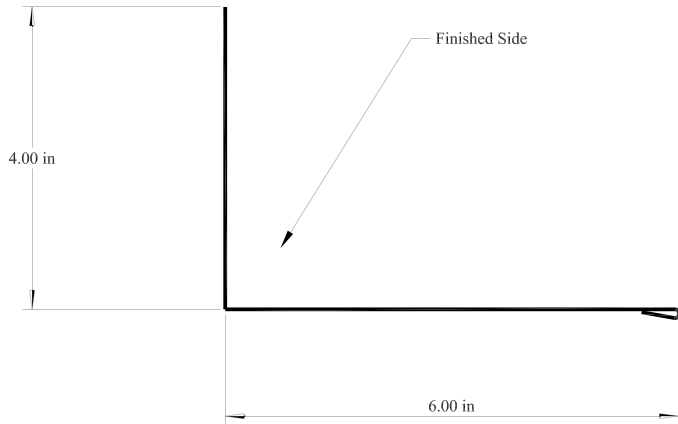

SIDEWALL FLASHING

*Not to scale

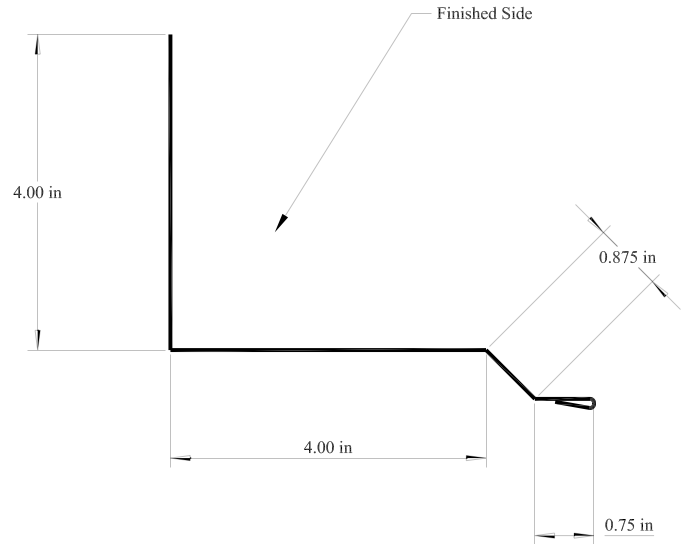

UNIVERSAL ENDWALL (TRANSITION) FLASHING

*Not to scale

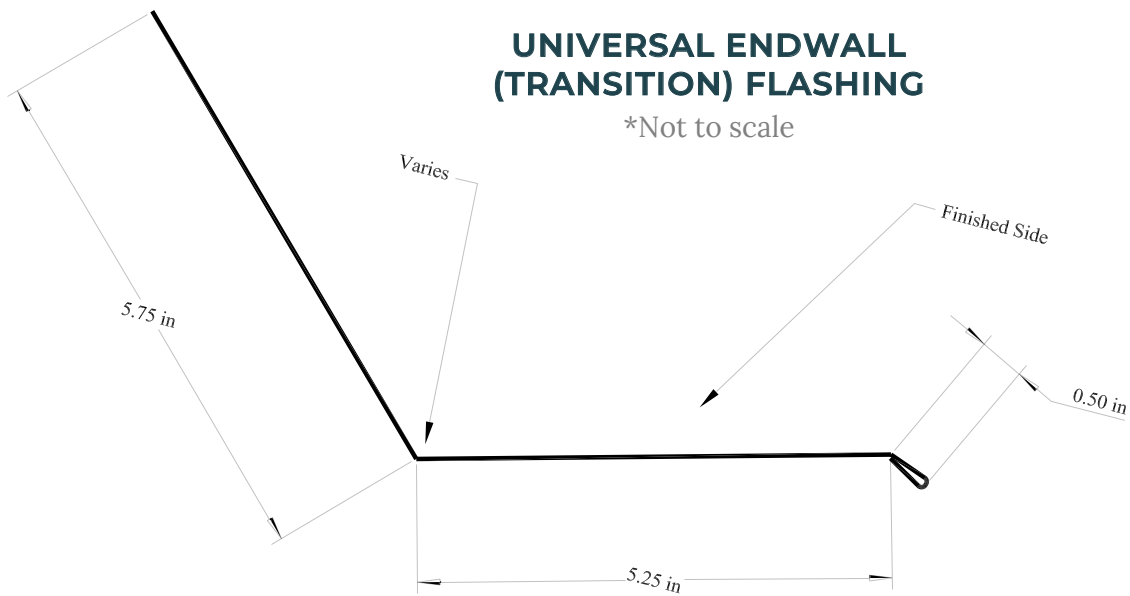

**CANNONBALL DOOR
TRACK COVER**

*Not to scale

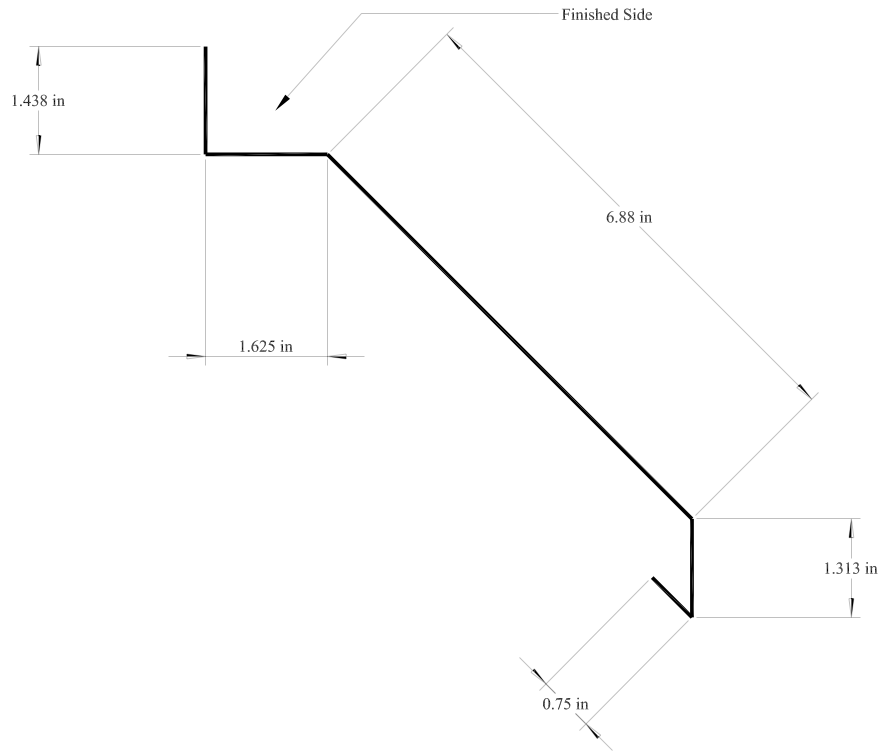

J-TRIM

*Not to scale

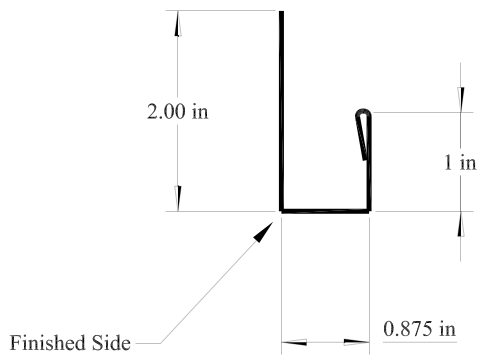

DRIP CAP

*Not to scale

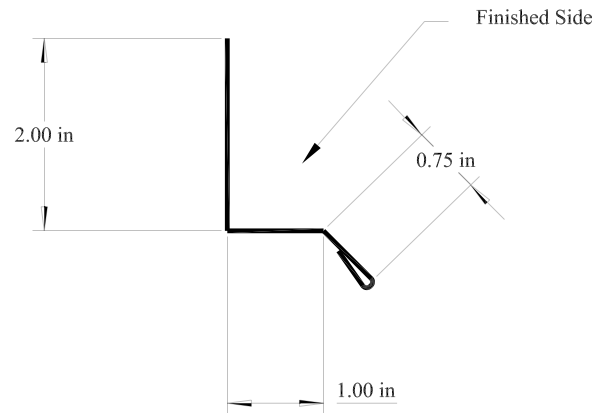

R-PANEL CORNER

*Not to scale

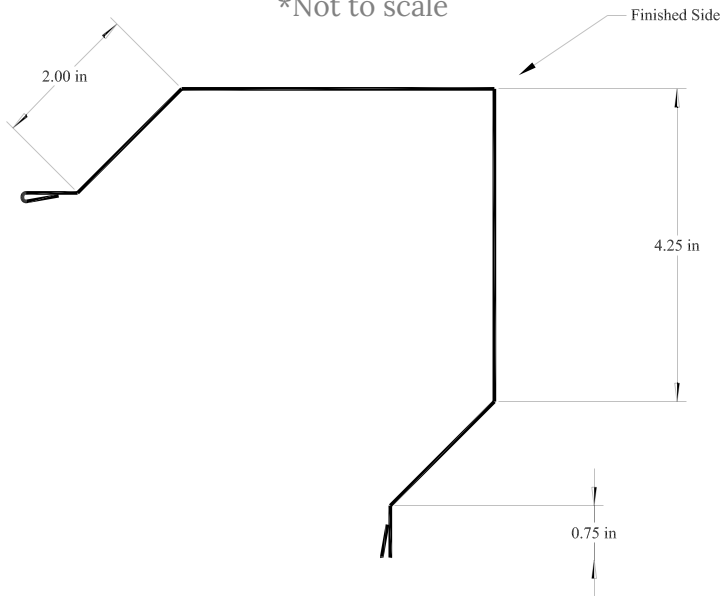

R-PANEL RAT GUARD

*Not to scale

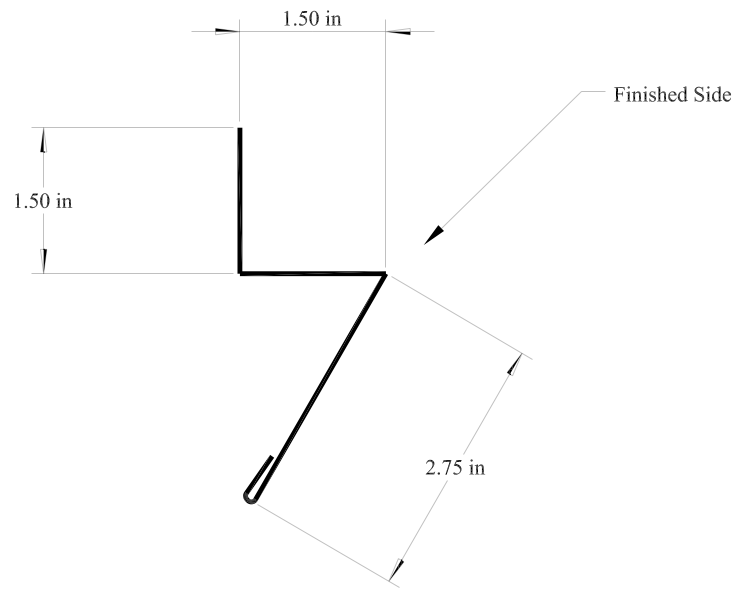

R-PANEL J TRIM

*Not to scale

